

101, 112f

Straight Arm Mounting Instructions

Part Numbers: MA1, 2, 5, 2R & 5R

1. If necessary, use Figure A for drill hole mounting positions and size.
2. Verify all parts are included with Figure B.
3. Disassemble and set aside optional nuts and washers holding the gasket.
4. Apply gasket to housing.
5. Thread the rods into the housing using the short threaded end.
6. Assemble as shown in Figure C, while routing the fixture wire through the assembly.
7. Place fender washers inside pole and secure with lockwashers and nuts.
8. Tighten the nuts of the assembly to 19 foot-pounds MAXIMUM.

BOLT HOLE PATTERN FOR SPARTAN FLOODS

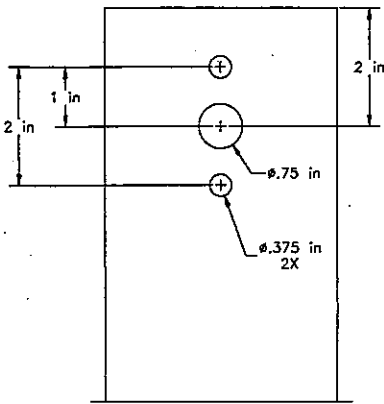

Figure A

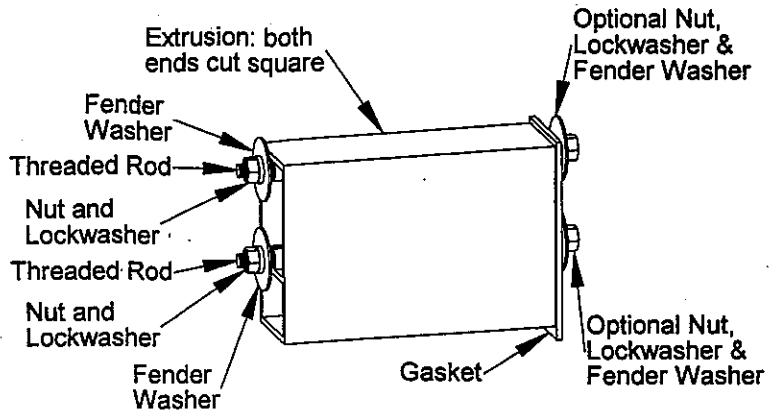

Figure B

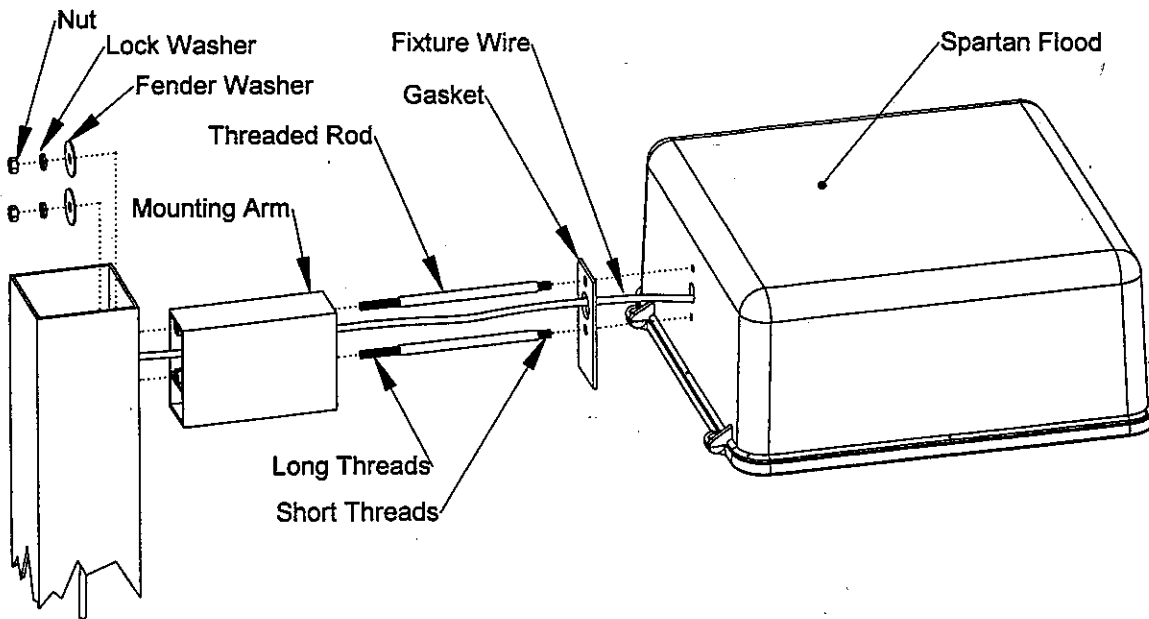

Figure C



C.E.W. LIGHTING, INC. 14040 Welch Road, Dallas, TX * 1-800-242-5267

A MANUFACTURER OF CEW AND SPARTAN BRAND HID LIGHTING PRODUCTS

IS0001X02RO-9906